

**NEW!
5000 BTUH
MODEL**

VORTEX A/C

New Model # 7770 Vortex A/C™ Offers Two-Stage Cooling Protection



Compared to a refrigerant-based air conditioner, the quiet operating Vortex A/C:

- Is 1/2 to 1/3 the cost
- Is less than 1/10 the size
- Installs in a fraction of the time
- Requires no electrical connections
- Has a warranty that's 10 times longer
- Uses no potentially harmful refrigerants

Provides below-ambient cooling protection in environments up to 80°C.



Patent Pending

Requiring only a compressed air supply to operate, the Vortex A/C quickly installs to keep electrical controls cool, clean and protected.

the Vortex A/C quickly installs on electrical control panels to maintain enclosure temperatures within a range of 80° to 90°F (27° to 32°C). The “no-downtime”, maintenance-free units incorporate vortex tube technology to convert filtered compressed air into a low pressure, refrigerated air stream distributed throughout the enclosure.

Vortec's new 5000 BTUH Vortex A/C model features dual vortex tube cooling units, each with its own reliable mechanical thermostat to provide a two-stage level of refrigeration. To conserve energy, the first stage offers 2500 BTUH cooling capacity and, if needed, a second stage activates to double the supply of refrigerated air to the enclosure. This patent pending design allows one cooler to mitigate the heat load, reducing the need or operating time for the unit to run at full cooling capacity.



Two-stage, vortex cooler design conserves energy and adds flexibility

refrigerated air in the cabinet. For example, the first stage cooler's output could be directed at a primary source of heat within the enclosure (PLC's, VFD's, transformers, etc.), and the second stage ducting could be routed for overall distribution of cold air throughout the panel. Refrigerated air entering the cabinet provides a light positive pressure to seal out contaminants, while hot air

Vortec has introduced its latest model to our lineup of UL Listed, Vortex A/C™ cooling systems for electrical enclosures. Requiring only a compressed air supply to operate,

the Vortex A/C quickly installs on electrical control panels to maintain enclosure temperatures within a range of 80° to 90°F (27° to 32°C). The “no-downtime”, maintenance-free units incorporate vortex tube technology to convert filtered compressed air into a low pressure, refrigerated air stream distributed throughout the enclosure.

The dual cold air outlets and ducting tubes provide for increased flexibility in directing

Dimensions

FRONT VIEW

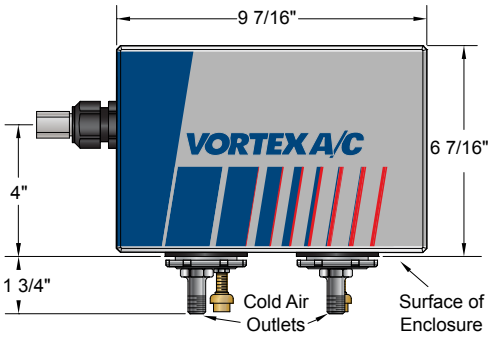

SIDE VIEW

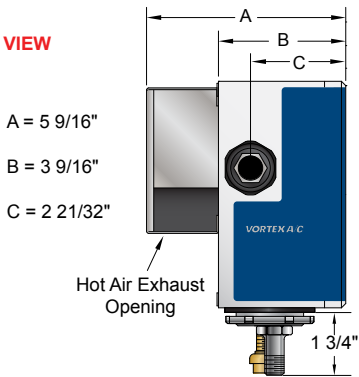

BACK VIEW

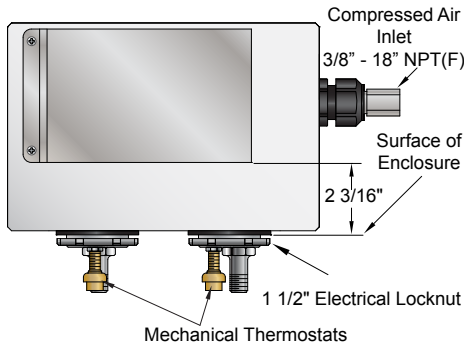

is expelled through a relief valve. Even when the Vortex A/C cycles off, “purge-air ports” in each of the unit’s two coolers can be opened to purge the cabinet of dust and dirt.

At a fraction of the size and cost of a refrigerant-based air conditioner, the Vortex A/C provides reliable, below-ambient cooling in environments up to 175°F (79°C). As with other Vortex A/C models, the 5000 BTUH unit is UL Listed for NEMA Type 4 and 4X rated electrical cabinets, and can be mounted on the top or side of the enclosure.

FRONT VIEW (MOUNTED)

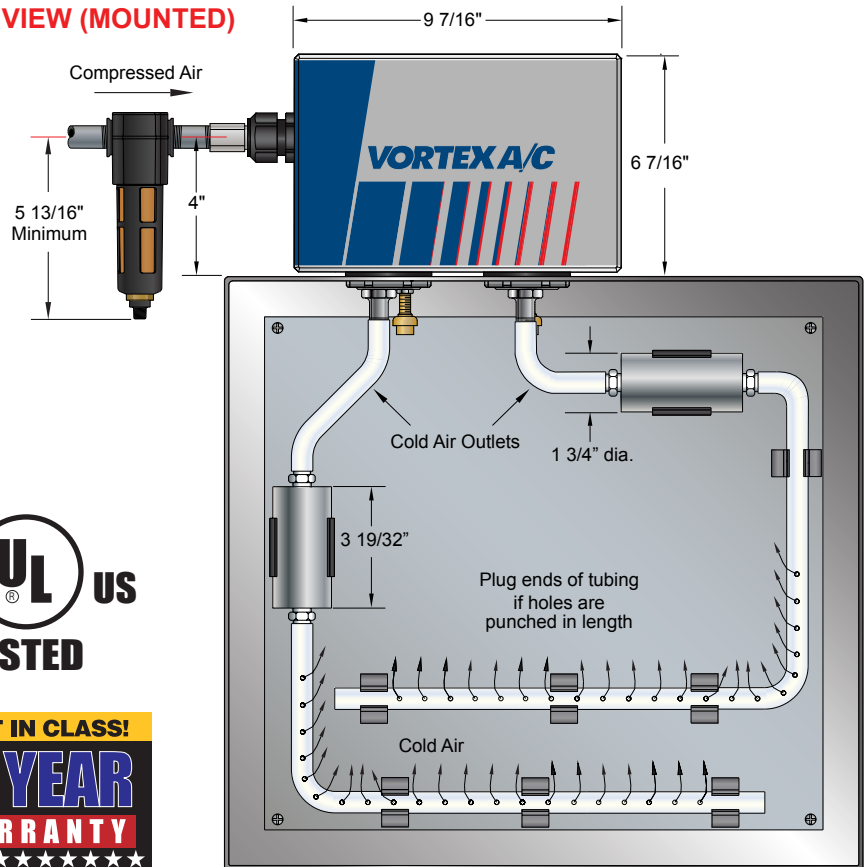

Specifications

MODEL NO. 7770

Cooling Capacity

BTUH 2500/5000
Kcal/hr. 625/1250

Air Consumption

SCFM 35/70
SLPM 991/1981

Compare The Differences

	VortexA/C™ # 7770	Refrigerant-based Air Conditioners
Physical size (in cubic inches)	268	3200 to 5200
Average installation time	20 min.	3 hours
Maximum ambient temperature	175°F (79°C)	131°F (55°C)
Operating noise level	62-64 dBA	62-64 dBA
Optional continuous enclosure purge	Yes	No
Weight	8.75 lb.	52 lbs. to 130 lbs.
Mounting Footprint	33.6 sq. in.	212 to 540 sq. in.
Warranty	10 Years	1 Year

